



VRE OPERATIONS BOARD MEETING

March 17, 2023

*The meeting will
begin at 9 a.m.*

Meeting materials are available at
vre.org/about/board/board-agenda-minutes/2023/March

PLEDGE OF ALLEGIANCE



ROLL CALL



Walter Alcorn
Fairfax County



Sarah Bagley
Alexandria



Andrea Bailey
Prince William County



Meg Bohmke
Stafford County

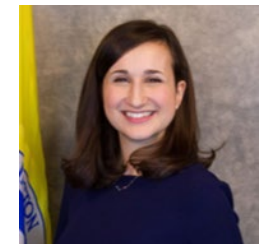

Katie Cristol
Arlington



Margaret Franklin
Prince William County



Monica Gary
Stafford County



Lori Hayes
Spotsylvania County



Matt Kelly
Fredericksburg



Jeanine Lawson
Prince William County



Mike McLaughlin
Commonwealth of Virginia



Alanna Mensing
Manassas Park



Ralph Smith
Manassas



Dan Storck
Fairfax County



James Walkinshaw
Fairfax County



SAFETY MOMENT



APPROVAL OF AGENDA

1. Pledge of Allegiance
2. Roll Call
3. Safety Briefing
4. Approval of the Agenda
5. Approval of Minutes from the February 17, 2023 VRE Operations Board Meeting
6. Chair's Comments
7. Chief Executive Officer's Report
8. VRE Riders' and Public Comment
9. Action Items
 - A. Authorization to Execute a Contract for Insurance Brokerage Services
 - B. Authorization to Execute a Contract for Renewal of Locomotive Head End Power Engine Systems
 - C. Authorization to Execute a Sole Source Contract for Positive Train Control Simulator Upgrades and Maintenance Services
 - D. Authorization to Amend the Contract for Engineering and Environmental Services for the Manassas Park Station Parking Expansion
 - E. Authorization to Execute a Contract for Construction of Manassas Park Station Parking Expansion
10. Information Items
 - A. Passenger Information and Messaging System
 - B. Marketing and Community Outreach 2023
 - C. Spending Authority Report
11. Closed Session
12. Operations Board Members' Time

APPROVAL OF MINUTES

February 17, 2023

Meeting with YouTube Livestream

Members Present

- Walter Alcorn (NVTC)
- Sarah Bagley (NVTC)
- Andrea Bailey (PRTC)
- Meg Bohmke (PRTC) *
- Katie Cristol (NVTC)
- Margaret Franklin (PRTC)
- Matt Kelly (PRTC)
- Jeanine Lawson (PRTC)
- Michael McLaughlin (VPRA)
- Alanna Mensing (PRTC)
- Ralph Smith (PRTC)
- Dan Storck (NVTC)
- James Walkinshaw (NVTC)

Members Absent

- Monica Gary (PRTC)
- Lori Hayes (PRTC)

*Participated virtually

Jurisdiction

- Fairfax County
- City of Alexandria
- Prince William County
- Stafford County
- Arlington County
- Prince William County
- City of Fredericksburg
- Prince William County
- Commonwealth of Virginia
- City of Manassas Park
- City of Manassas
- Fairfax County
- Fairfax County

Jurisdiction

- Stafford County
- Spotsylvania County



James Walkinshaw
VRE Operations Board Chair
Fairfax County



CHAIR'S COMMENTS

- Welcome to the VRE Operations Board March meeting.
- A reminder that the meeting is being livestreamed.
- The Finance Committee will meet following adjournment of the Operations Board meeting.



James Walkinshaw
VRE Operations Board Chair
Fairfax County



CEO REPORT

- **Safety**
- **Performance**
- **Ridership**



Rich Dalton
VRE CEO



CEO REPORT – SAFETY

Celebrating

7

Injury-Free
YEARS

& Counting



CEO REPORT – SAFETY

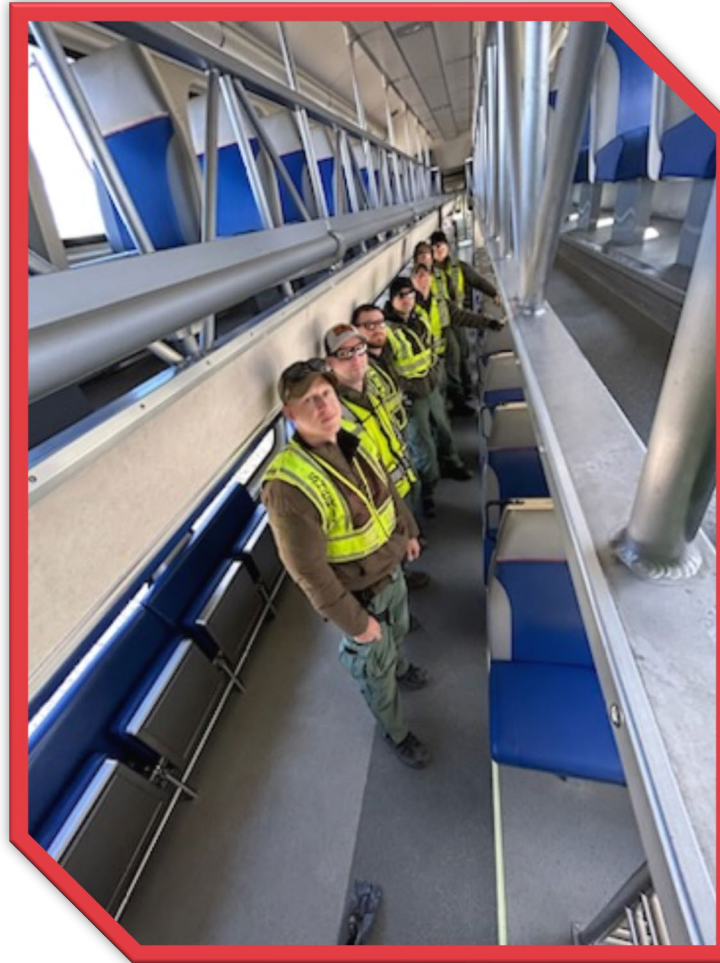
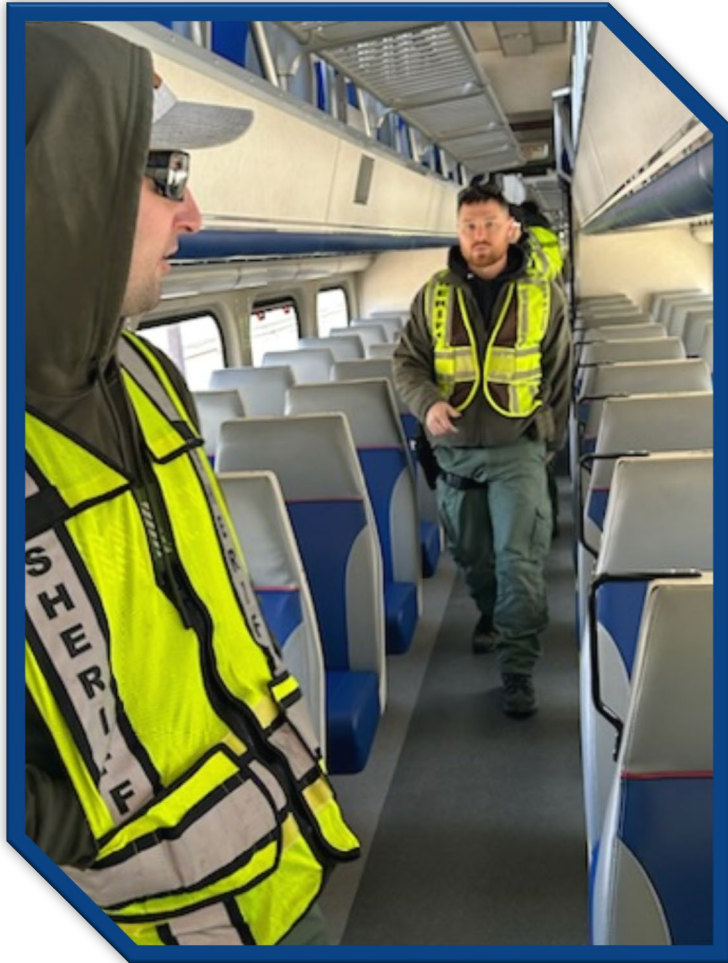

CEO REPORT – SAFETY

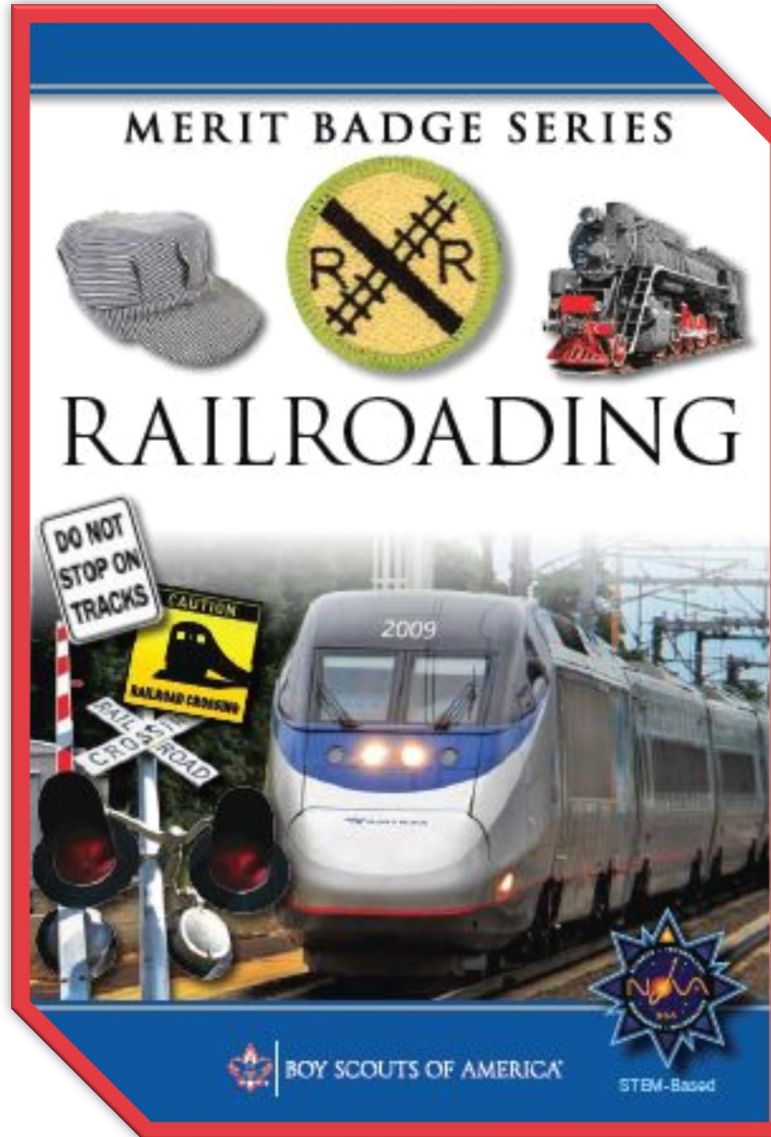

CEO REPORT – ON-TIME PERFORMANCE

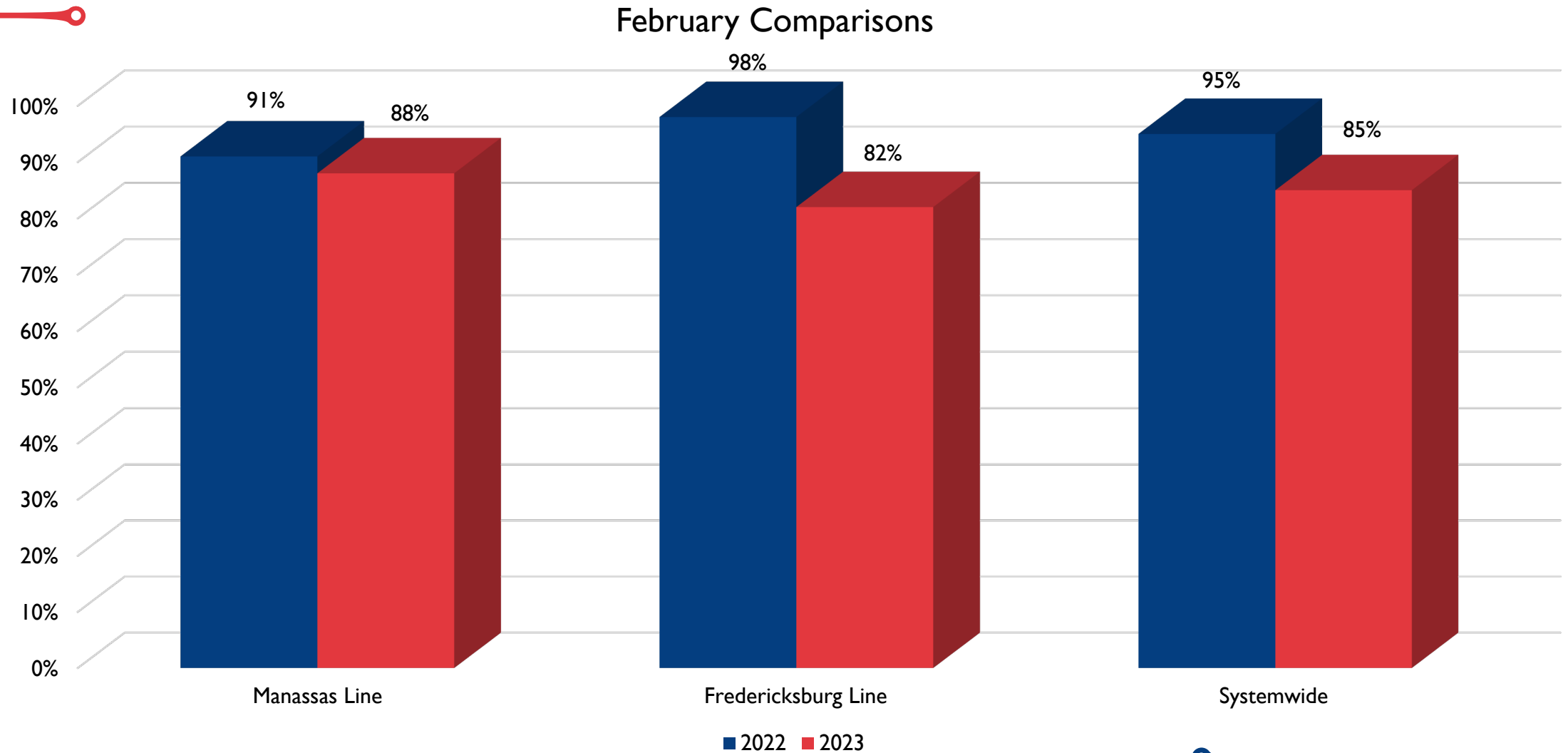

CEO REPORT – ON-TIME PERFORMANCE

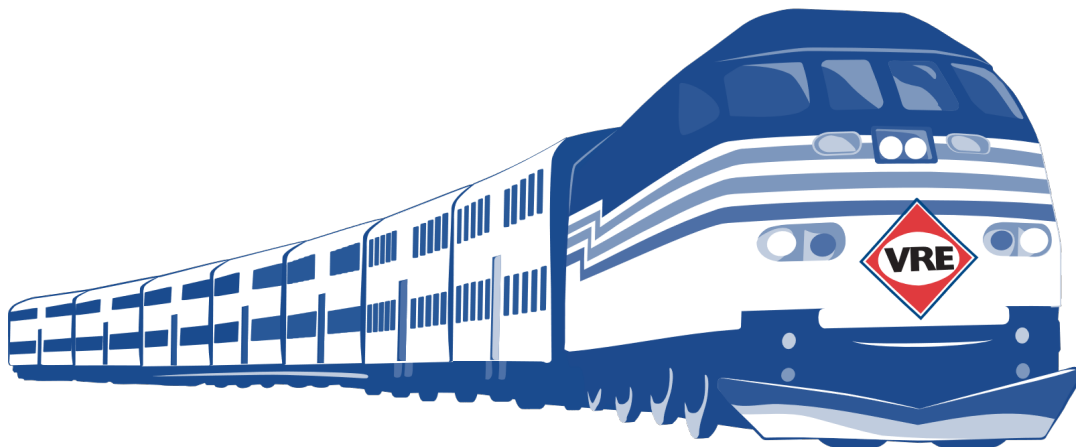

	DEC. 2022	JAN. 2023	FEB. 2023
	21 Days	20 Days	19 Days
<i>LATE TRAINS</i>			
Manassas	44	48	37
Fredericksburg	33	43	54
Systemwide	77	91	91
<i>AVERAGE MINUTES DELAYED</i>			
	15	17	19
<i># TRAINS 30+ MINUTES LATE</i>			
	4	12	14
<i>OTP</i>			
Manassas	85%	85%	88%
Fredericksburg	89%	87%	82%
Systemwide	87%	86%	85%



CEO REPORT – ON-TIME PERFORMANCE

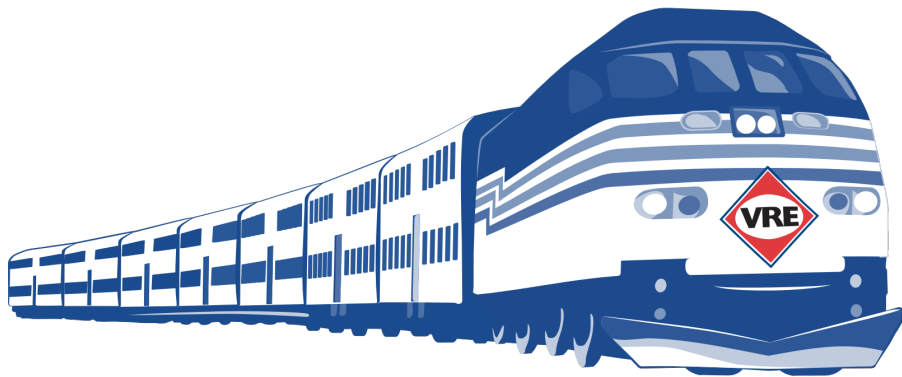

		DEC.	JAN.	FEB.	TOTAL #	TOTAL %
		21 Days	20 Days	19 Days	60 Days	
CAUSE		# OF TRAINS DELAYED				
Congestion		62	51	48	161	62.2%
Switch/Signal Issue		4	16	19	39	15.0%
Positive Train Control	Primary	1	4	1	6	5.0%
	Cascading	-	5	2	7	
Police Activity		3*	7**	-	10	3.9%
Speed Restrictions		-	-	9	9	3.5%
Dispatcher		-	5	2	7	2.7%
Maintenance of Way		-	-	7	7	2.7%
Mechanical	Primary	2	1	2	5	2.7%
	Cascading	-	2	-	2	
Weather		4	-	-	4	1.5%
Tree Strike		-	-	1	1	0.4%
Trespasser(s)		1	-	-	1	0.4%
Total Delays		77	91	91	259	100.0%

*Report of Vehicle on Tracks (12/14) & Medical Emergency (12/15) **Car stuck on tracks (1/18), Amtrak passenger issue (1/23), Medical emergency (1/13) & Trespasser (1/26)

CEO REPORT – MONTHLY RIDERSHIP

Exclusive of Boardings at Alexandria and Crystal City

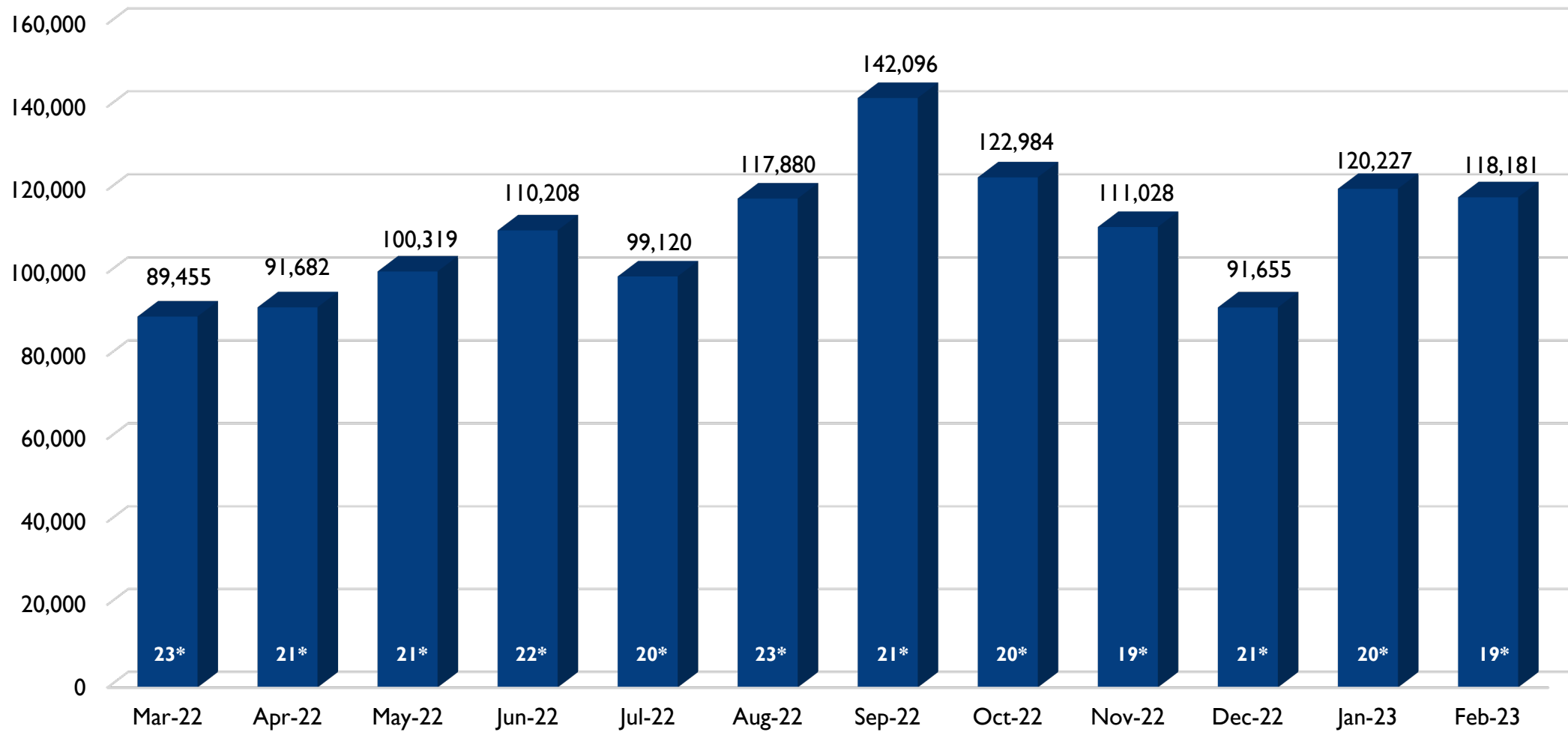

*service days per month



CEO REPORT – AVERAGE DAILY RIDERSHIP

Exclusive of Boardings at Alexandria and Crystal City

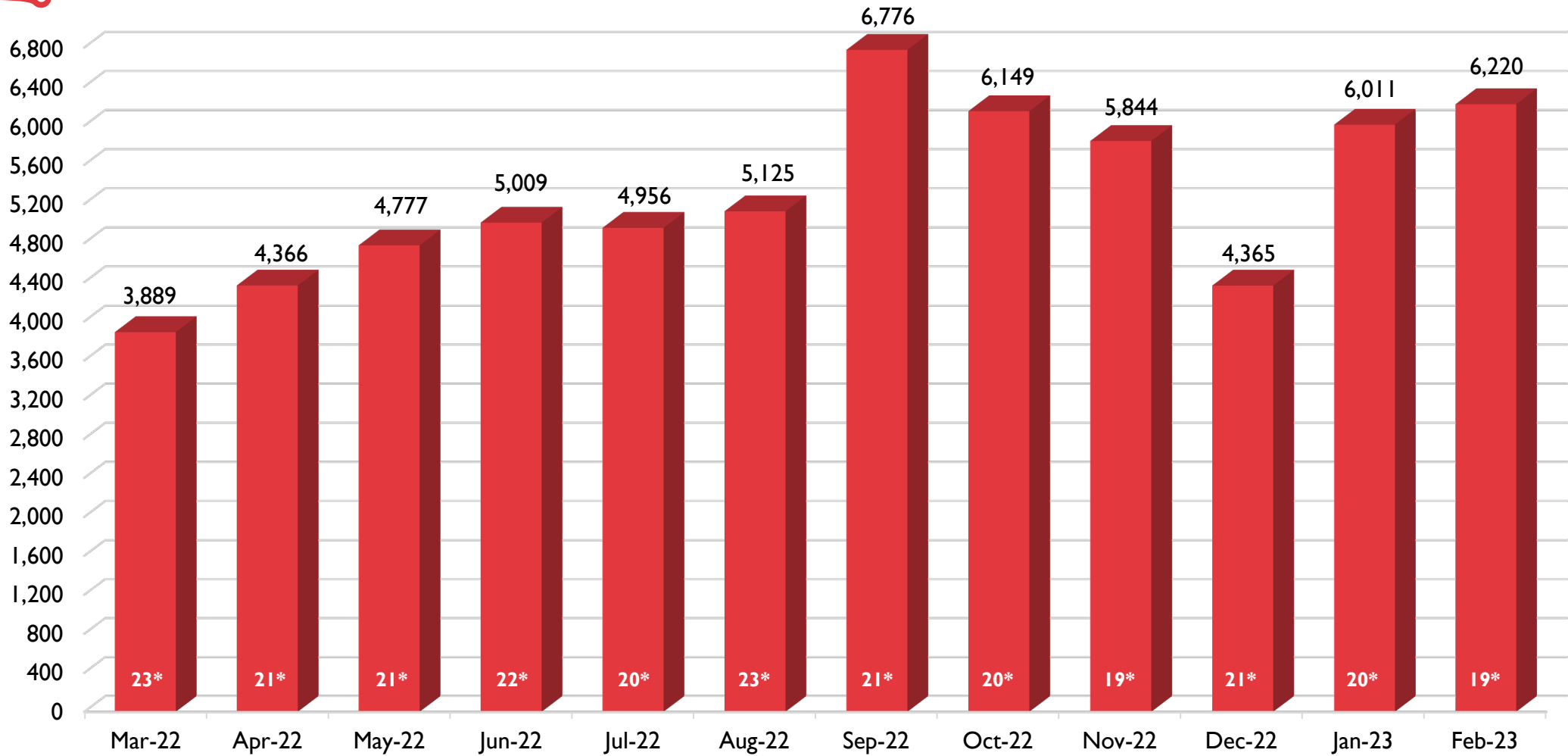

*service days per month



CEO REPORT – AVERAGE DAILY RIDERSHIP

Percentage of Ridership By Day

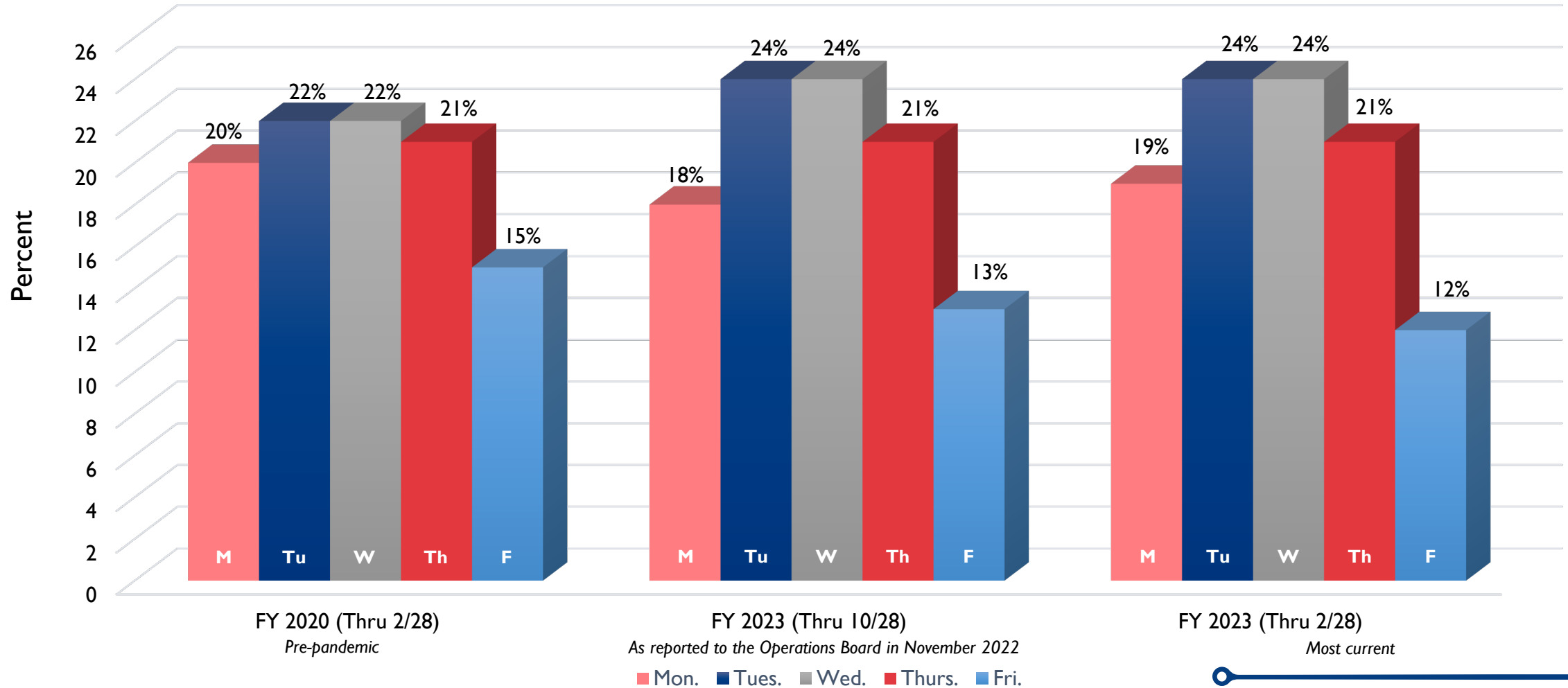

CEO REPORT – AVERAGE DAILY RIDERSHIP

Percentage of Ridership By Line

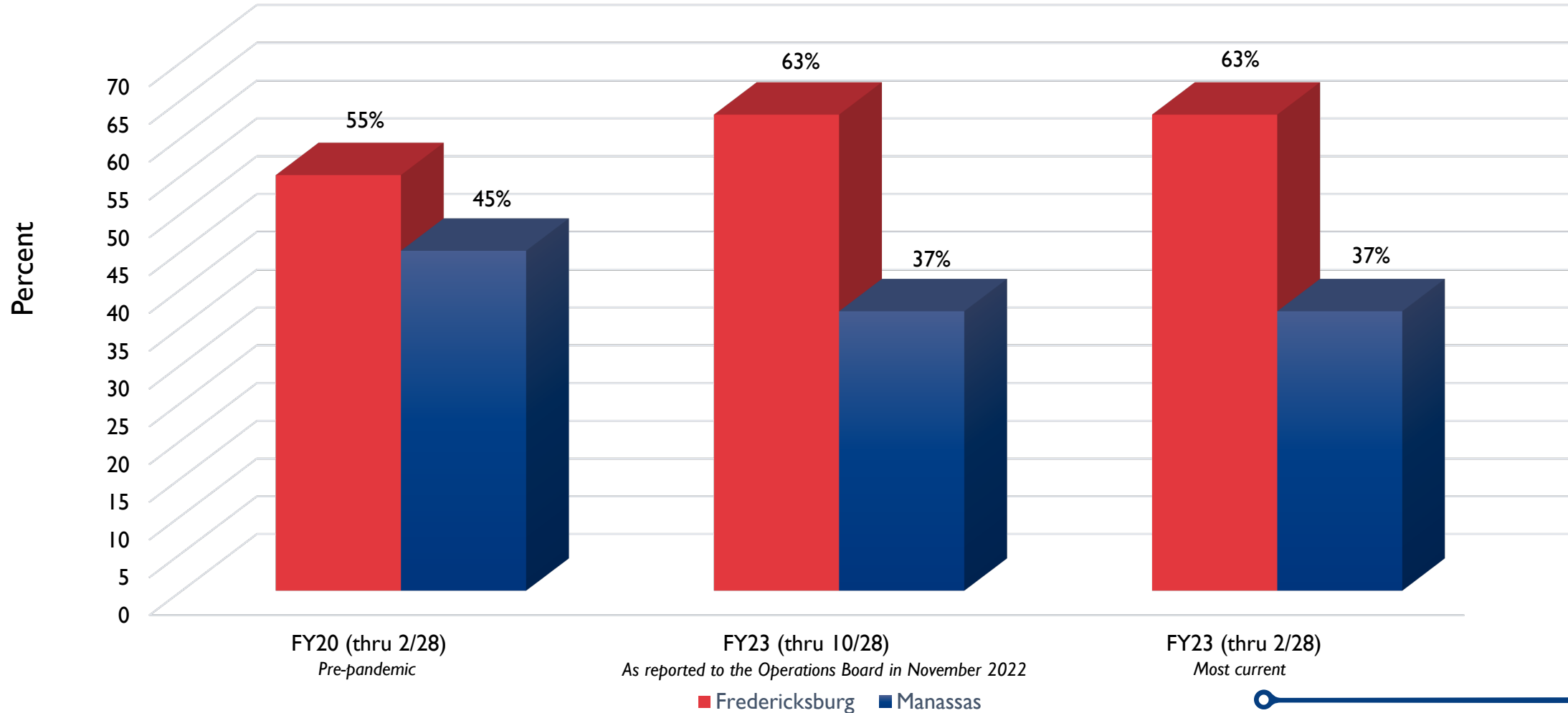

CEO REPORT – COMMENTS



VRE RIDERS' & PUBLIC COMMENT

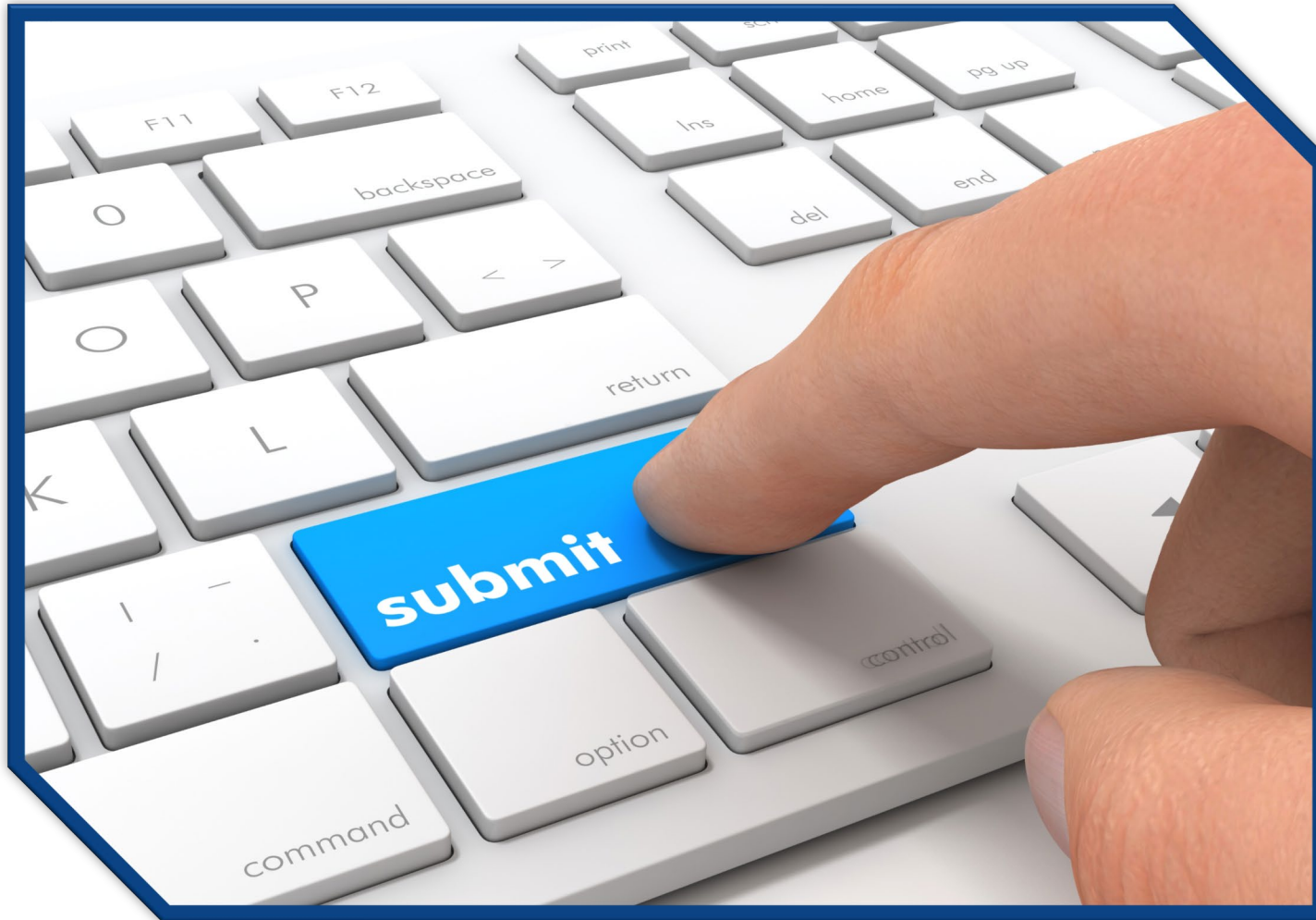

James Walkinshaw
VRE Operations Board Chair
Fairfax County



AUTHORIZATION TO EXECUTE A CONTRACT FOR INSURANCE BROKERAGE SERVICES

Recommendation:

The VRE Operations Board is asked to authorize the CEO to execute a contract with Aon Risk Services, Inc. (Aon) of Washington, DC for insurance brokerage services in the amount of \$425,000, plus a 10 percent contingency of \$42,500, for a total amount not to exceed \$467,500, for a base period of three years and two one-year option periods, with the CEO exercising the option periods at his discretion.

Summary:

VRE procures multiple insurance coverages annually, including property, terrorism, liability, automobile and cyber. This contract is for brokerage services to help VRE engage with underwriters for the procurement of proper insurance coverages and the administration of the various policies, as well as risk management consulting to better understand the market and improve our risk management profile.



James Walkinshaw
VRE Operations Board Chair
Fairfax County



Rich Dalton
VRE CEO



AUTHORIZATION TO EXECUTE A CONTRACT FOR RENEWAL OF LOCOMOTIVE HEAD END POWER ENGINE SYSTEMS

Recommendation:

The VRE Operations Board is asked to authorize the CEO to execute a contract with Higher Power Industries, Inc. of Yonkers, NY for renewal of locomotive head end power (HEP) engine systems in the amount of \$6,297,081, plus a 10 percent contingency of \$629,708, for a total amount not to exceed \$6,926,789.

Summary:

The VRE Operations Board adopted a lifecycle maintenance strategy for VRE rolling stock in January 2014 to maintain VRE locomotives and passenger railcars at the highest level of reliability throughout the equipment lifecycle. These HEP engine systems are reaching the end of their useful life under VRE's lifecycle maintenance program. This authorization will allow VRE to award a contract for the renewal of 21 HEP engine systems for VRE's fleet of 20 MP36 locomotives. Twenty HEP engine systems will be installed by the contractor, and one will be kept as a spare.



James Walkinshaw
VRE Operations Board Chair
Fairfax County



Rich Dalton
VRE CEO



AUTHORIZATION TO EXECUTE A SOLE SOURCE CONTRACT FOR POSITIVE TRAIN CONTROL SIMULATOR UPGRADES AND MAINTENANCE SERVICES

Recommendation:

The VRE Operations Board is asked to authorize the CEO to execute a sole source contract with PS Technology, Inc. of Louisville, CO for positive train control (PTC) simulator upgrades and maintenance services in the amount of \$216,513, plus a 10 percent contingency of \$21,651, for a total amount not to exceed \$238,164.

Summary:

VRE implemented a comprehensive PTC training program to meet the requirements of the Rail Safety Improvement Act of 2008. The locomotive simulator solution provided by PS Technology (PST), which was purchased by VRE following Operations Board authorization in February 2018, serves as an integral part of VRE's crew training program. PST's solution was previously qualified for use by one of VRE's host railroads, Norfolk Southern Railway, but requires an upgrade to include the training requirements for VRE's other host railroads, CSX Transportation and Amtrak.



James Walkinshaw
VRE Operations Board Chair
Fairfax County



Rich Dalton
VRE CEO



AUTHORIZATION TO AMEND THE CONTRACT FOR ENGINEERING AND ENVIRONMENTAL SERVICES FOR THE MANASSAS PARK STATION PARKING EXPANSION

Recommendation:

The VRE Operations Board is asked to authorize the CEO to execute a contract amendment with Vanasse Hangen Brustlin, Inc. (VHB), of Vienna, VA, for engineering and environmental services for the Manassas Park Station Parking Expansion Project in the amount of \$596,618, plus a 10 percent contingency of \$59,662, for a total amount of \$656,280 for construction administration services. This will increase the total authorization for this contract from \$2,784,986 to a total amount not to exceed \$3,441,266.

Summary:

This action will provide funding for construction administration services, which includes review of submittals from the construction contractor. Such submittals received during construction require review by the Engineer-of-Record and may result in additional design.



James Walkinshaw
VRE Operations Board Chair
Fairfax County



Rich Dalton
VRE CEO



AUTHORIZATION TO EXECUTE A CONTRACT FOR CONSTRUCTION OF MANASSAS PARK STATION PARKING EXPANSION

Recommendation:

The VRE Operations Board is asked to authorize the CEO to execute a contract with Manhattan Construction Company of Arlington, VA for construction of the Manassas Park parking expansion in the amount of \$24,996,294, plus a 10 percent contingency of \$2,499,629, for a total amount not to exceed \$27,495,923.

Summary:

Authorization will allow VRE to contract for construction of the Manassas Park parking expansion, which includes the parking garage and connecting pedestrian bridge.

The City of Manassas Park, through its Economic Development Authority, has entered into a ground lease with VRE for a 2.5-acre parcel of land located across the railroad tracks from the station. VRE will utilize the land to construct a structured parking garage with three above-ground levels and one below-ground level. The garage will consist of approximately 540 parking spaces above ground for use by VRE riders and approximately 196 below-grade parking spaces for use by the city.



James Walkinshaw
VRE Operations Board Chair
Fairfax County



Rich Dalton
VRE CEO



PASSENGER INFORMATION AND MESSAGING SYSTEM

Integration of VMS, VRE Mobile and VRE.org



Where we are now

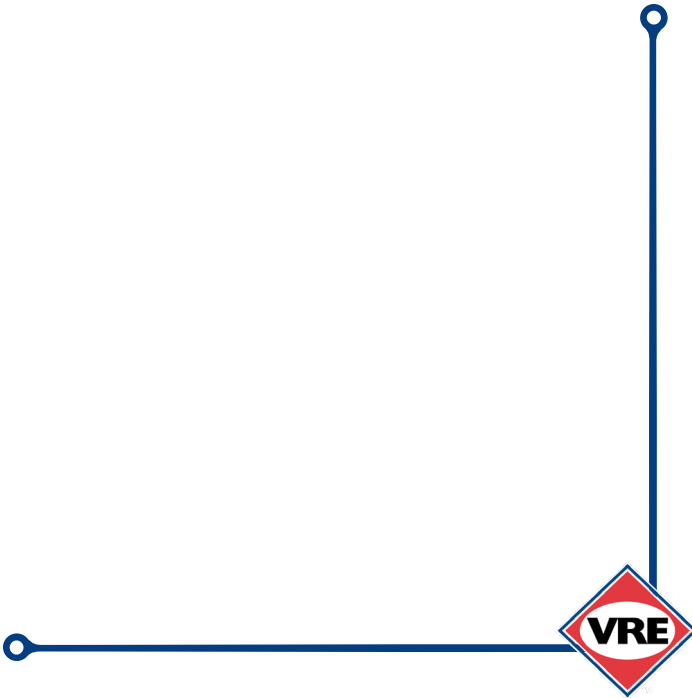

Where we are now

VRE Mobile



americaneagle.com.

Mobile Tickets



americaneagle.com.

Web Portal



- Push Notifications
- Passenger Counters
- Parking Counters
- GTFS
- Amtrak Train Data

Trip Tools



Where we are now

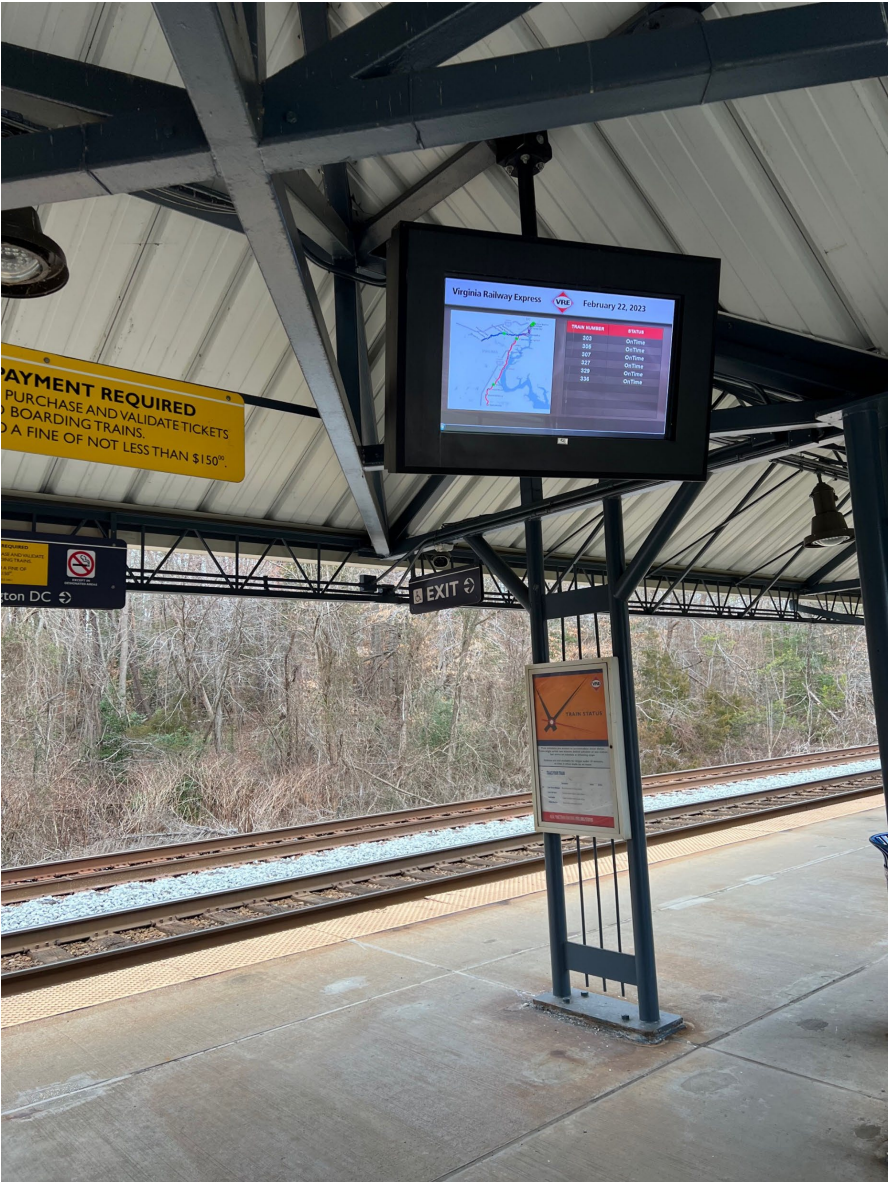

Where we are now



Where we are now

ALEXANDRIA STATION CURRENTLY 44 2:52 PM

TIME	TRACK	ROUTE	DESTINATION	STATUS	TRACK
2:27 PM	92	Silver Star	New York	Now 3:21p	
2:56 PM	95	N.E. Regional	Norfolk	Boarding	3
3:03 PM	303	VA Railway Exp	Spotsylvania	On Time	3
3:25 PM	91	Silver Star	Miami	On Time	
3:43 PM	327	VA Railway Exp	Broad Run	On Time	3
3:53 PM	305	VA Railway Exp	Spotsylvania	On Time	3

CONNECTING TRANSIT INFORMATION

TIME	ROUTE	TO	TIME	ROUTE	TO
2:52 PM	28A	EAST TO KING STREET - OLD TOWN STATION	2:55 PM	71	WVCC VIA OLD TOWN CIRCULATOR & KING ST
2:52 PM	8EX	NORTH TO KING STREET - OLD TOWN STATION	3:00 PM	30	BRADDOCK METRO VIA DUKE ST & OLD TOWN
2:52 PM	8EX	NORTH TO KING STREET - OLD TOWN STATION	3:05 PM	30	VAR DOWN METRO VIA OLD TOWN CIRCULATOR & KING ST
2:53 PM	BLU	LARGO TOWN CENTER	3:05 PM	31	KING ST METRO VIA KING ST
2:53 PM	YEL	GREENBELT	3:08 PM	32	KING ST METRO VIA COMMONWEALTH AVE
2:54 PM	YEL	GREENBELT	3:10 PM	71	WVCC VIA OLD TOWN CIRCULATOR & KING ST



Key Objectives

- Enhance passenger experience, ease learning curve/anxiety
- Consistent styling across all technology platforms
- Drive passengers to utilize VRE Mobile
- Safe and simplified maintainability

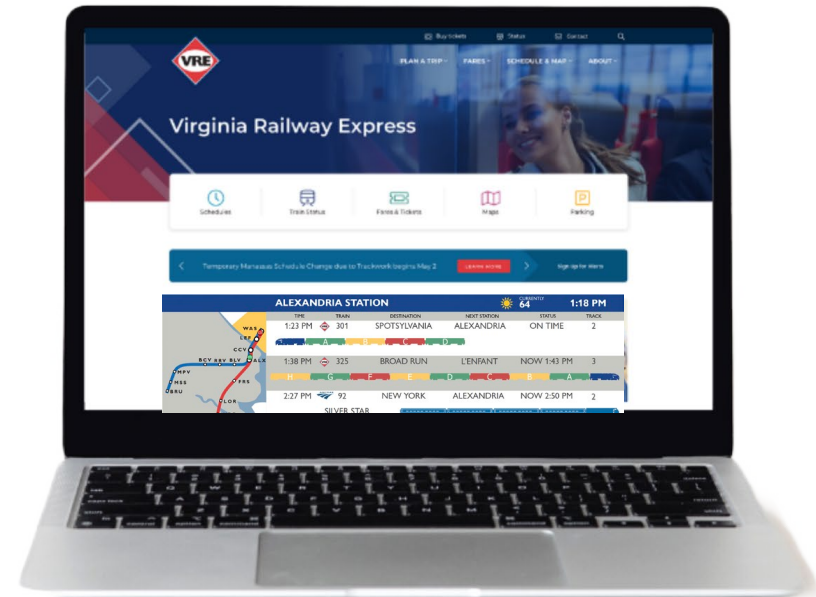
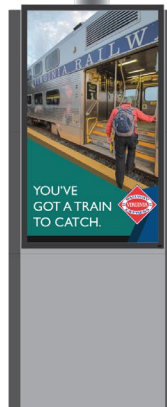
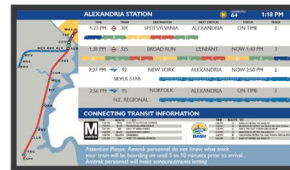

ALEXANDRIA STATION



CURRENTLY
64

1:18 PM



TIME	TRAIN	DESTINATION	NEXT STATION	STATUS	TRACK
1:23 PM	301	SPOTSYLVANIA	ALEXANDRIA	ON TIME	2
1:38 PM	325	BROAD RUN	L'ENFANT	NOW 1:43 PM	3
2:27 PM	92	NEW YORK	ALEXANDRIA	NOW 2:50 PM	2
SILVER STAR					
2:56 PM	95	NORFOLK	ALEXANDRIA	ON TIME	3
N.E. REGIONAL					

CONNECTING TRANSIT INFORMATION

TIME	ROUTE	TO
1:20 PM	NH2	EAST TO NATIONAL HARBOR
1:25 PM	BLUE	FRANCONIA SPRINGFIELD
1:27 PM	28A	EAST TO KING STREET
1:30 PM	BLUE	DOWNTOWN LARGO
1:30 PM	YELLOW	GREENBELT
1:32 PM	29N	WEST TO VIENNA STATION



TIME	ROUTE	TO
1:20 PM	31	KING ST METRO VIA KING ST
1:30 PM	30	BRADDOCK METRO VIA DUKE ST/ OLD TOWN
1:30 PM	31	NVCC VIA OLD TOWN CIRCULATOR
1:35 PM	31	BRADDOCK METRO VIA KING ST
1:40 PM	30	VAN DORN METRO VIA OLD TOWN CIRCULATOR
1:50 PM	31	KING ST METRO VIA KING ST

Attention Please: Amtrak personnel do not know what track your train will be boarding on until 5 to 10 minutes prior to arrival. Amtrak personnel will make announcements letting

Platform + Interactive Displays

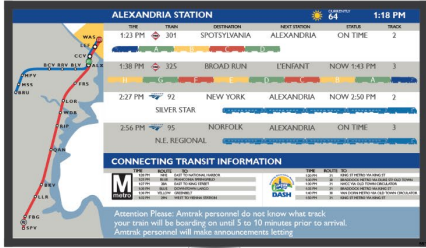

VMS Screen

- Phase 2 evolution of VMS POC
- Real-time trip information
- Platform mounted, not hung from overhead



Interactive Display Screen

- ADA Friendly
- Always present QR code for conversion to VRE Mobile
- FAQ for new riders
- Interactive Fare Chart
- Sleep mode display rotating VRE messaging
- Replaces legacy posters/cases

Platform + Interactive Displays

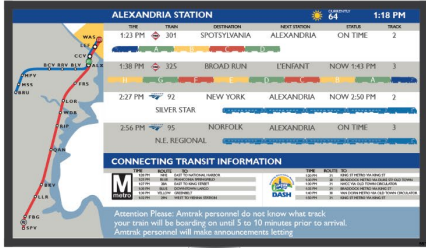

VMS Screen

- Phase 2 evolution of VMS POC
- Real-time trip information
- Platform mounted, not hung from overhead



Interactive Display Screen

- ADA Friendly
- Always present QR code for conversion to VRE Mobile
- FAQ for new riders
- Interactive Fare Chart
- Sleep mode display rotating VRE messaging
- Replaces legacy posters/cases



Platform + Interactive Displays

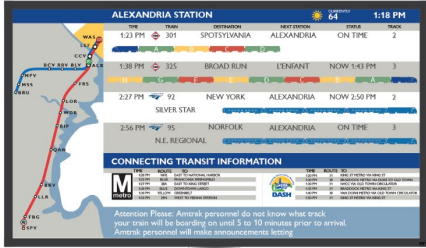

VMS Screen

- Phase 2 evolution of VMS POC
- Real-time trip information
- Platform mounted, not hung from overhead



Interactive Display Screen

- ADA Friendly
- Always present QR code for conversion to VRE Mobile
- FAQ for new riders
- Interactive Fare Chart
- Sleep mode display rotating VRE messaging
- Replaces legacy posters/cases



Platform + Inter

ALEXANDRIA STATION

ARRIVAL	DEPART	STATION	STATUS	TRACK	
1:23 PM	301	SPOTSVYLVANIA	ALEXANDRIA	ON TIME	2
1:38 PM	325	BROAD RUN	LYNCHBURG	NOW 1:43 PM	3
2:27 PM	92	NEW YORK	ALEXANDRIA	NOW 2:50 PM	2
2:56 PM	95	NORFOLK	ALEXANDRIA	ON TIME	1

CONNECTING TRANSIT INFORMATION

MODE	LINE	STATION	STATUS
METRO	144	ROCKY MOUNTAIN	ON TIME
DMU	144	ROCKY MOUNTAIN	ON TIME
DMU	144	ROCKY MOUNTAIN	ON TIME

Attention: Please, Amtrak personnel do not know what track your train will be boarding on until 3 to 10 minutes prior to arrival. Amtrak personnel will make announcements on-site.

YOUR VRE

29TH ANNUAL MANASSAS RAILWAY FESTIVAL
June 3, 2023

TRAIN RIDES
FOOD TRUCKS
LOCAL VENDORS
LIVE MUSIC

9201 CENTER STREET, MANASSAS, VA 20110

Icons for accessibility: clock, train, wheelchair, QR code

You've got a train to catch.
CONTACT VRE 703-684-1001

YOUR VRE

MANASSAS VIRGINIA RAILWAY EXPRESS

29TH ANNUAL MANASSAS RAILWAY FESTIVAL
June 3, 2023

TRAIN RIDES
FOOD TRUCKS
LOCAL VENDORS
LIVE MUSIC

9201 CENTER STREET, MANASSAS, VA 20110

SCHEDULES | TBA | ADA View | DOWNLOAD VRE MOBILE

You've got a train to catch.
Contact VRE 703-684-1001

ys

OC

from overhead

conversion to VRE Mobile

VRE messaging



Platform + Interactive Displays

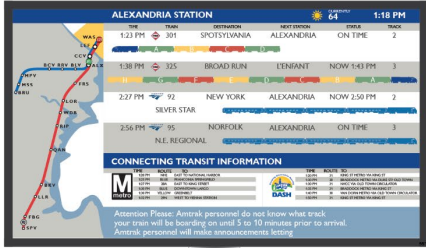

VMS Screen

- Phase 2 evolution of VMS POC
- Real-time trip information
- Platform mounted, not hung from overhead



Interactive Display Screen

- ADA Friendly
- Always present QR code for conversion to VRE Mobile
- FAQ for new riders
- Interactive Fare Chart
- Sleep mode display rotating VRE messaging
- Replaces legacy posters/cases

Platform + Interactive Displays

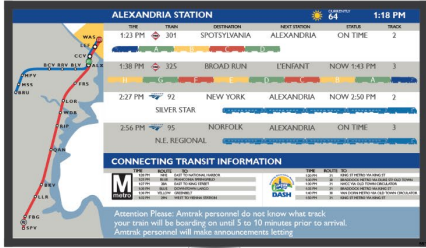

VMS Screen

- Phase 2 evolution of VMS POC
- Real-time trip information
- Platform mounted, not hung from overhead



Interactive Display Screen

- ADA Friendly
- Always present QR code for conversion to VRE Mobile
- FAQ for new riders
- Interactive Fare Chart
- Sleep mode display rotating VRE messaging
- Replaces legacy posters/cases

VRE Mobile – Beyond Ticketing

- VRE Mobile - Phase 2
 - VMS information
 - Real time seat availability
 - New train status map
 - Connecting transit

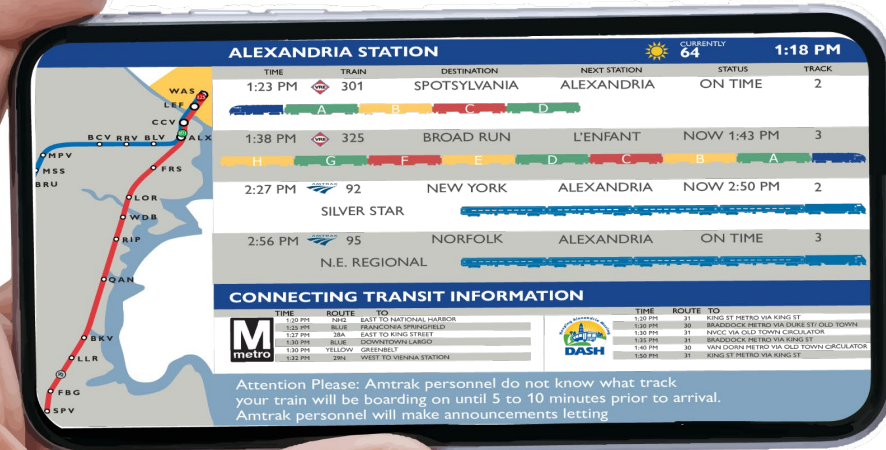

- VRE Mobile - Phase 2
 - Push notifications
 - Passenger counts
 - Parking availability
 - Real-time schedule updates

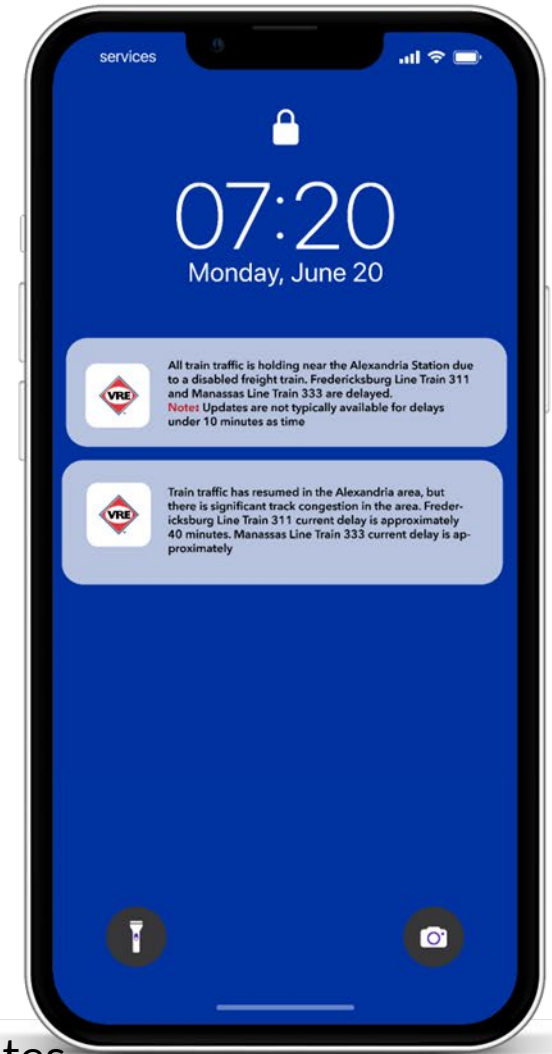

VRE Website 2.0

- Revised website with updated look and feel
- Passenger experience consistent across platforms

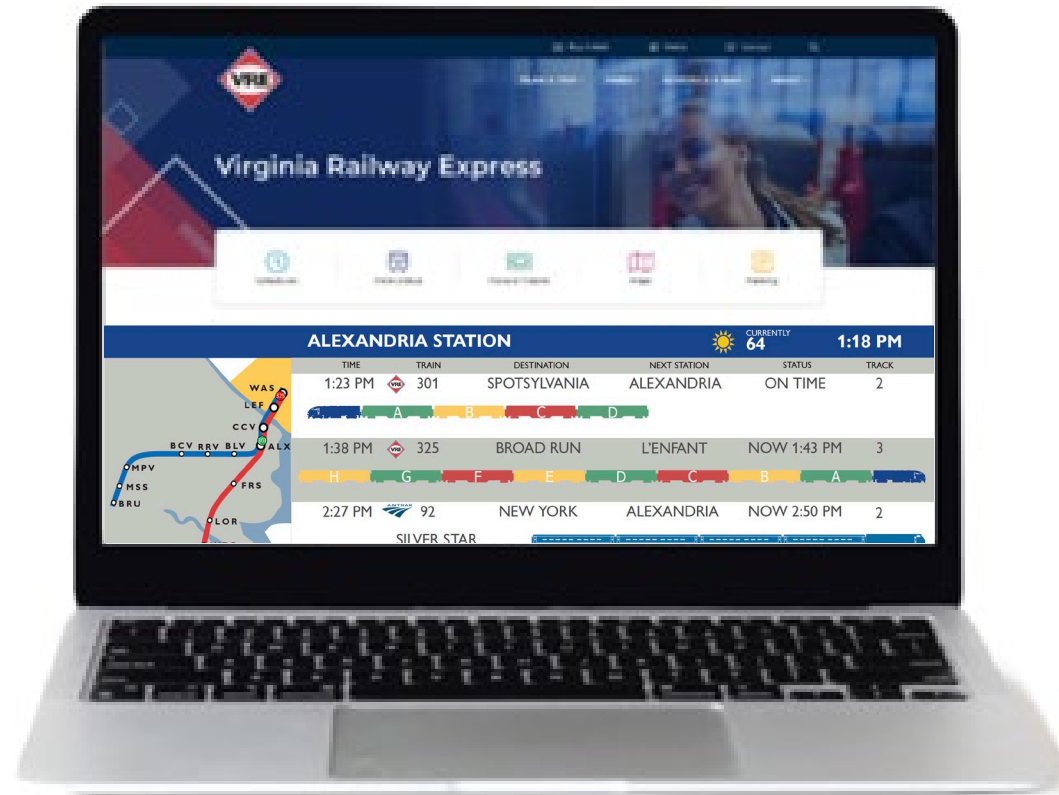

Maintainability – Improved Safety

- Goal: eliminate need for multiple people working off the ground
- Mechanism for lowering the screen
- Telescoping /pivoting
- Safety locking pin
- Safe and easy replacement /maintenance

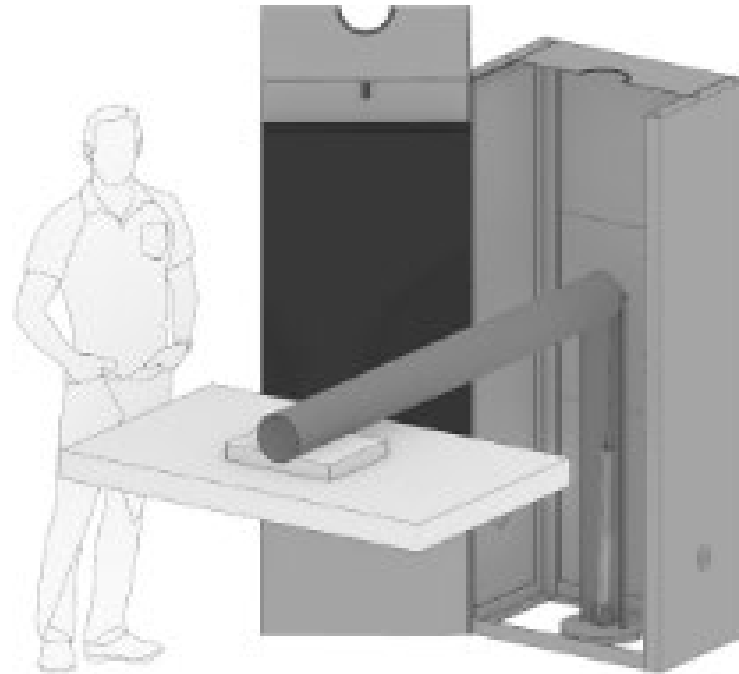
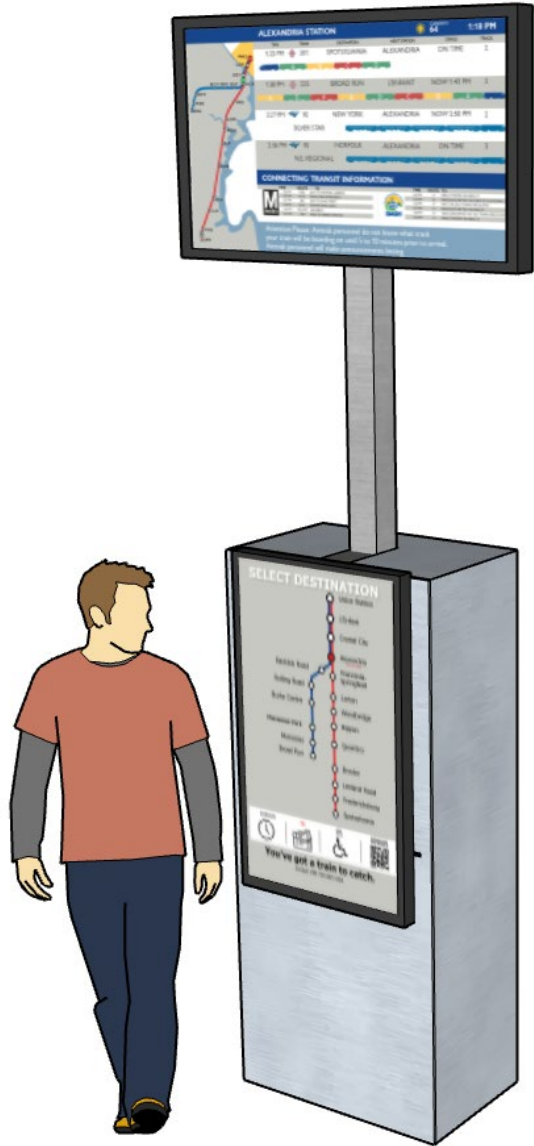

Next Steps

- **VRE Mobile Phase 2 – Contract Amendment**
- **VRE.org – Contract Amendment**
- **Platform + - Release RFP**
 - Mobile Notifications
 - Real-Time Schedule and train updates
 - Automatic Passenger Counters
 - Real-time Parking Status
 - Amtrak train information





QUESTIONS?

[VRE.ORG](https://vre.org)





Vision 2023 - Marketing Initiatives

- **Broadcast Advertising**
- **Social Media**
- **Direct Mail (EDDM)**
- **VRE Branded Content**
- **Community Outreach**





Broadcast

Local Radio Advertisement

- Pinpoint Targeting
- Cost-Effective
- Radio Ads Are Effective

SXM Streaming Everywhere

- Largest audio marketplace in the US
- Precision targeting (age, gender, geography connects with our best customer.
- 98M streaming listeners

Podcast

- 66M podcast listeners



Digital Audio Listening Has Skyrocketed

Digital audio's easy accessibility, wide range of content, and multiple platforms is drawing huge audiences.

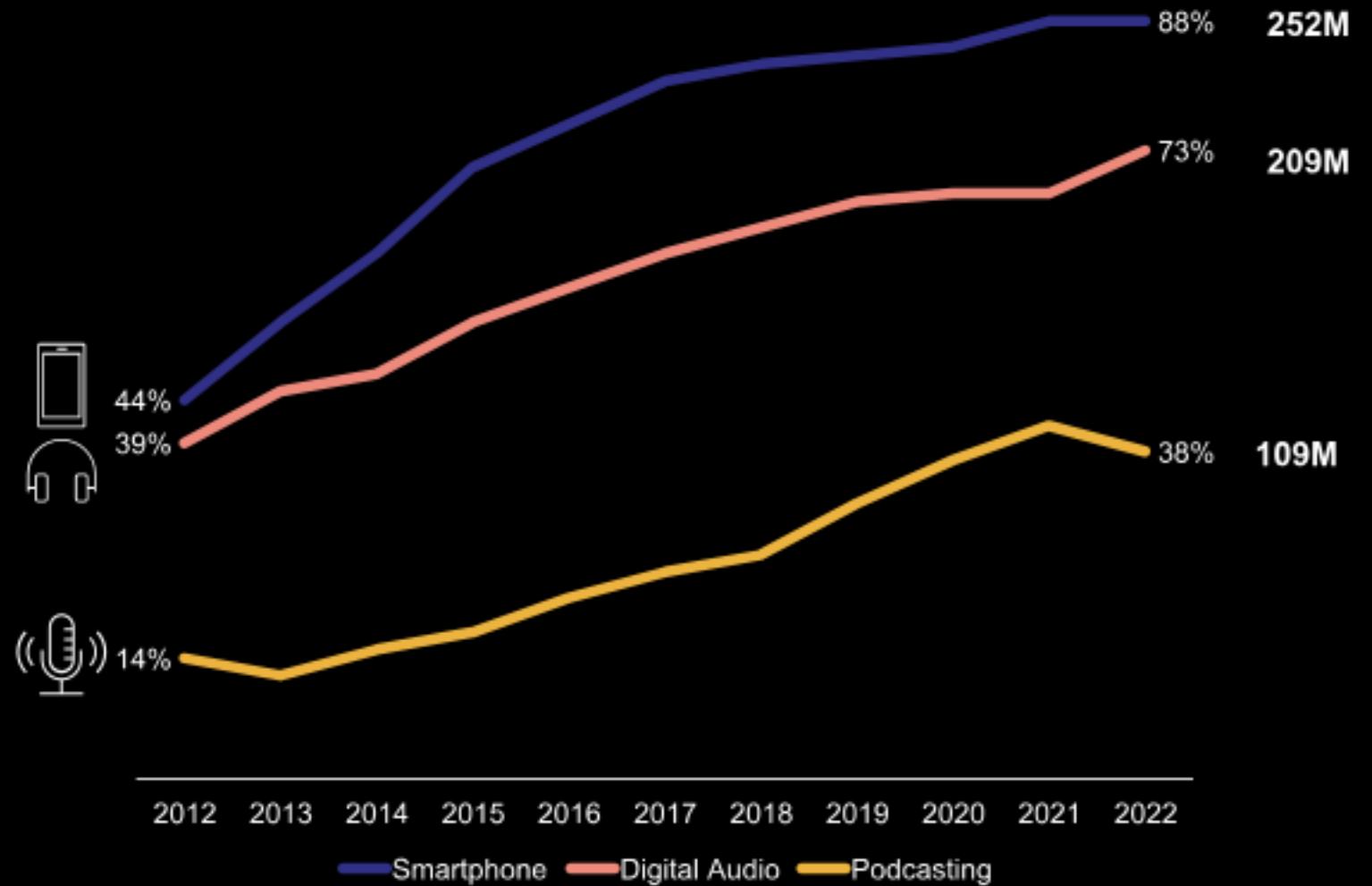



Social Media

2022 Year in Review Update

- 2M impressions
- Post reach across network 632K
- Average post engagement rate 4.13%

2023 Goals

- Raise brand awareness
- Enhance brand loyalty
- Increase community engagement
- VRE micro and nano influencers





Every Door Direct Mail

Why Direct Mail?

- The average response rate is between 2.7% and 4.4%.
- 73% of American consumers prefer being contacted by brands via mail.
- 40% of direct mail recipients read or at least scan the mail they get.
- Customers are preferring hand-held marketing communications.

Plans for VRE

- Determine the zip codes of potential areas and target them.
- A three-month pilot program will begin in early April.





VRE Branded Content

What is branded content?

- Marketing strategy that involves creating and sharing content across several media that discuss the brand's values and mission, often evoking emotions in viewers or readers.

Benefits

- Greater audience reach
- It's authentic and builds trust
- It has viral potential
- Builds a stronger relationship between the brand and customers





Community Outreach

- **April 1st** City of Manassas 150th Birthday Celebration
- **May 7th** The Great Train Race in Fredericksburg
- **June 3rd** Manassas Railway Festival
- **September (Date TBD)** Fredericksburg Association of Realtors Expo
- **October 8th** Clifton Day
- **October (Date TBD)** Northern Virginia Association of Realtors Expo
- **October (Date TBD)** Prince William Association of Realtors Expo





Collaboration

DRPT- Discover Transit Campaign

NVTC- Marketing Campaign

- **Radio Ads**
- **Social**
- **Targeted Marketing**





Thank You!

“Vision with action can change the world”



SPENDING AUTHORITY REPORT

On September 18, 2020, the VRE Operations Board approved increasing the CEO's delegated spending authority from \$100,000 to \$200,000. It was resolved as part of that increased delegation that any purchase or contract award in the range of \$50,000 to \$200,000 would be communicated to the Board as an information item.

- On February 18, 2023, VRE executed a sole source contract with Adams & Westlake Limited in the amount of \$181,870 to acquire new vestibule curtains and roller hooks for VRE's fleet of passenger rail cars. A fleet-wide changeout of the vestibule curtains and associated hardware is needed due to wear and tear as the result of aging. The vestibule curtains are utilized on the interior of each trainset and are installed in the passageway between two rail cars for the purpose of providing an added barrier between the inside and outside environments.



Rich Dalton
VRE CEO



OPERATIONS BOARD CLOSED SESSION

Pursuant to the Virginia Freedom of Information Act (Section 2.2-3711.A(1) of the Code of Virginia), I move that the VRE Operations Board convene a closed meeting for the purpose of discussing...



Meg Bohmke
Vice Chair
Stafford County



OPERATIONS BOARD CLOSED SESSION

The livestream will recommence following this portion of the meeting



OPERATIONS BOARD CLOSED SESSION

The VRE Operations Board certifies that, to the best of each member's knowledge and with no individual member dissenting, at the just concluded closed session:

- 1. Only public business matters lawfully exempted from open meeting requirements under the Freedom of Information Act were discussed; and,**
- 2. Only such public business matters as were identified in the motion by which the closed session was convened were heard, discussed or considered.**



Meg Bohmke

Vice Chair
Stafford County



OPERATIONS BOARD MEMBERS' TIME



Walter Alcorn
Fairfax County



Sarah Bagley
Alexandria



Andrea Bailey
Prince William County



Meg Bohmke
Stafford County



Katie Cristol
Arlington



Margaret Franklin
Prince William County



Monica Gary
Stafford County



Lori Hayes
Spotsylvania County



Matt Kelly
Fredericksburg



Jeanine Lawson
Prince William County



Mike McLaughlin
Commonwealth of Virginia



Alanna Mensing
Manassas Park



Ralph Smith
Manassas



Dan Storck
Fairfax County



James Walkinshaw
Fairfax County



**THE MARCH 17, 2023 MEETING OF
THE VRE OPERATIONS BOARD
IS ADJOURNED**



[VRE.ORG](https://vre.org)



MARCH 17, 2023
FINANCE COMMITTEE MEETING



[VRE.ORG](https://vre.org)

